

Setting up your work area

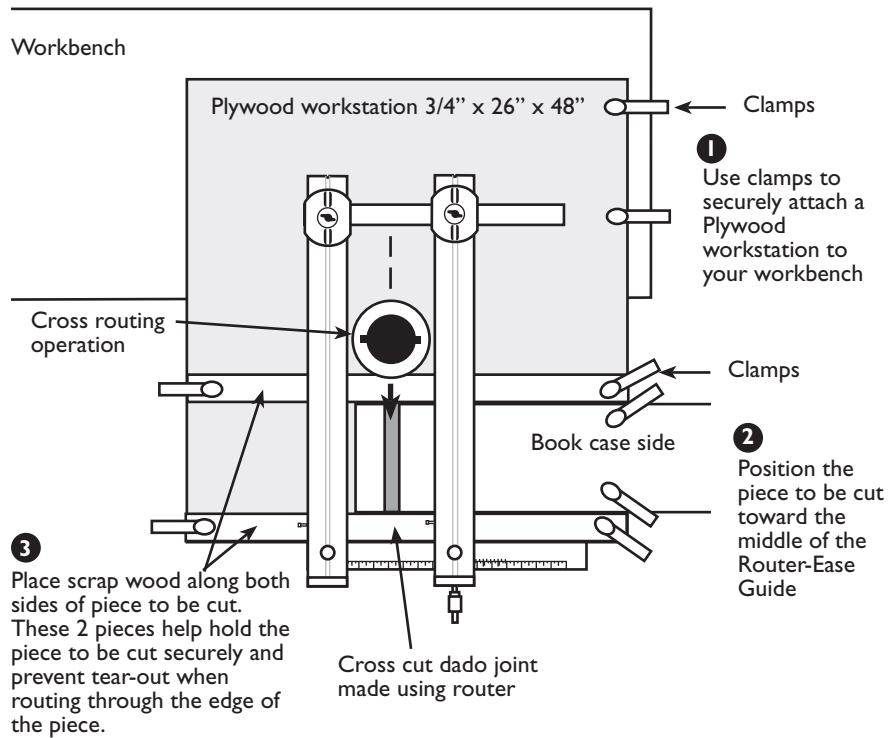

Using the Router-Ease Guide System

Cross cut operation (stop dado cut).

Tool Set-up — work the tool from left to right.

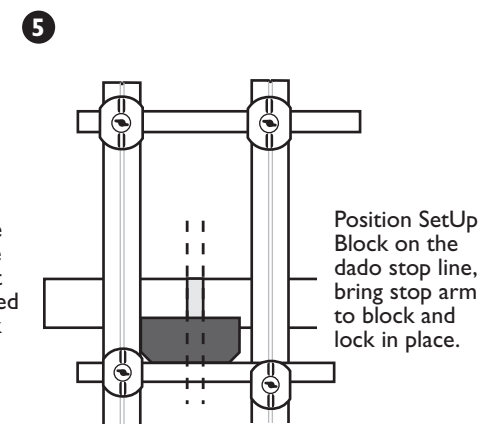
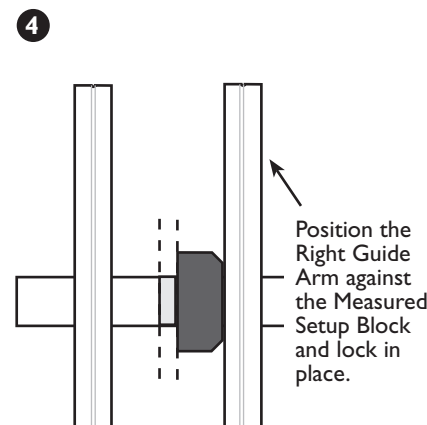
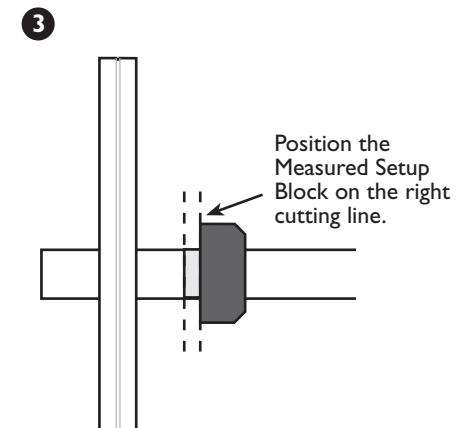
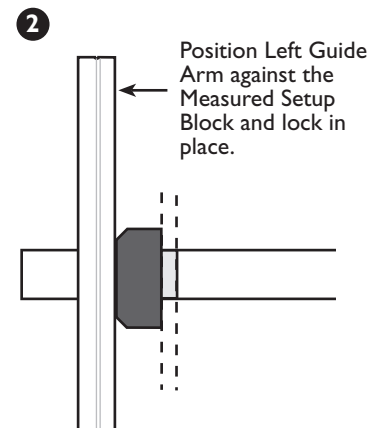
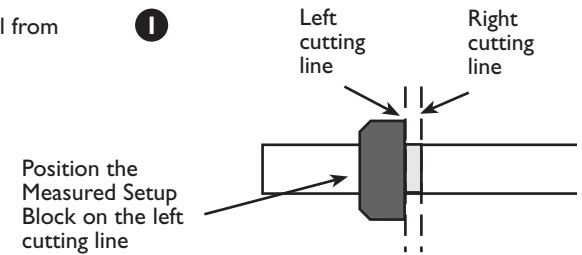

Measured Setup Block Applications

